

Improving the Efficiency of Thermoelectric Generator using Perturb and Observe MPPT Algorithm

(Meningkatkan Kecekapan Penjana Termoelektrik Menggunakan Algoritma MPPT Perturb dan Observe)

Nurul Izzah Izzati Zaihan, Tengku Norliza Tengku Mohamad* & Fakroul Ridzuan Hashim

*Department of Electrical and Electronic Engineering,
Faculty of Engineering, Universiti Pertahanan Nasional Malaysia (UPNM), Kem Sungai Besi,
57000 Kuala Lumpur, Malaysia*

**Corresponding author: norli@upnm.edu.my*

Received 2nd September 2024, Received in revised form 2nd September 2024

Accepted 1st October 2024, Available online 30th November 2024

ABSTRACT

Maximum Power Point Tracking (MPPT) is a crucial strategy for maximizing energy extraction from Thermoelectric Generators (TEGs). Various MPPT techniques, such as Interval Type 2 Fuzzy Logic Controller (IT2FLC), Extremum Seeking Control (ESC), and Perturb and Observe (P&O), have been developed to achieve optimal power output from TEG systems. Among these methods, the P&O technique stands out due to its ease of implementation and control scheme, cost-effectiveness, and high output power. This paper proposes a design that integrates TEG arrays, boost converters, and the P&O algorithm to optimize power extraction from TEG systems. The performance of the system utilizing the P&O based MPPT technique is compared to the system without MPPT under the same operating conditions, highlighting the significant of MPPT in enhancing TEG efficiency. The results demonstrate that the P&O algorithm effectively increases the efficiency of MPPT in TEG systems. This study was conducted using the MATLAB/Simulink environment.

Keywords: Thermoelectric generator; MPPT; P&O; DC-DC boost converter; MATLAB/Simulink

ABSTRAK

Penjejakan Titik Kuasa Maksimum (MPPT) adalah strategi penting untuk memaksimumkan pengekstrakan tenaga daripada penjana Thermoelectric Generator (TEG). Pelbagai teknik MPPT, seperti Interval Type 2 Fuzzy Logic Controller (IT2FLC), Extremum Seeking Control (ESC), dan Perturb and Observe (P&O) telah dibangunkan untuk mencapai keluaran kuasa maksimum daripada system TEG. Antara kaedah-kaedah ini, teknik P&O amat diberi perhatian kerana pelaksanaan dan skim kawalannya yang mudah, keberkesanan kos dan kuasa keluarannya yang tinggi. Kertas kerja ini mencadangkan reka bentuk yang menyepadukan tatasusunan TEG, penukar rangsangan, dan algoritma P&O untuk mengoptimumkan pengekstrakan kuasa system TEG. Prestasi sistem yang menggunakan Teknik MPPT berasaskan P&O dibandingkan dengan system tanpa MPPT di bawah keadaan operasi yang sama bagi menyerlahkan kepentingan MPPT dalam meningkatkan kecekapan TEG. Hasil kajian menunjukkan bahawa algoritma P&O berkesan meningkatkan kecekapan MPPT dalam system TEG. Kajian ini dijalankan menggunakan perisian MATLAB/Simulink.

Kata Kunci: Penjana termoelektrik; MPPT; P&O; Penukar rangsangan DC-DC; MATLAB/Simulink

INTRODUCTION

In recent years, renewable energy technology has become crucial and received high demand due to the industrial revolution. In addition, it also plays an important role in clean energy applications (Mamur & Çoban, 2020). Among renewable energy sources solar energy is the main contributor and the most prevalent source due to its simplicity and capacity. Not only that, the generation of electric power from

thermoelectric generator (TEG) has also increased and gained more attention globally due to its ability to convert the heat energy into electrical energy.

TEGs are devices that converts heat directly into electrical energy using the principle of the thermoelectric effect (Polibatam (Organization) et al., n.d.). The thermoelectric effect is the phenomenon in which a temperature difference across a material produces an electric potential.

TEGs operate based on the Seebeck effect, which states that an electric current is produced when a temperature gradient is applied across a thermoelectric material (Miao et al., 2021). Compared to other power generation technologies, TEGs typically produce relatively low electrical power. They have an efficiency ranging from 5% to 10%, meaning they can convert only a small fraction of heat energy into electricity (Ahiska & Mamur, 2014). Implementing an effective Maximum Power Point Tracking (MPPT) algorithm such as Perturb & Observe (P&O) method, enables TEGs to operate at their highest possible power point under varying conditions, thereby significantly improving their energy conversion efficiency. This improvement is crucial as it enhances the overall efficiency of the energy generation process, making TEGs more effective and feasible in real-world applications.

Despite their lower efficiency, TEGs offer several advantages, including simplicity, reliability, and no moving parts, which make them suitable for specific applications (Chen et al., 2016; Mamur & Ahiska, 2015). Improving TEGs efficiency through the implementation of MPPT algorithms not only optimizes the utilization of existing energy resources but also contributes to the global transition toward greener energy solutions. As a clean and reliable source of energy with minimum environmental impact, TEGs play a significant role in advancing sustainable energy technologies.

The capability of thermoelectric energy converters to harness heat from the transportation or industrial sectors and convert it into electricity makes them as a relevant technology in this fields (Champier, 2017; Jouhara et al., 2021). TEGs are utilized across a wide range of industries, including automotive, aerospace, and remote sensing, as well as upcoming technologies like wearables. As TEG efficiency improves, their potential for widespread adoption increases, making them a more feasible option for various applications. Enhanced TEG efficiency also contributes to improve energy security by providing a reliable source of electricity, particularly in remote or off-grid areas, thereby reducing dependence on traditional fossil fuels.

However, the widespread use of TEG technology is constrained by two significant challenges: high material costs and low efficiency (Mamur & Çoban, 2020). Addressing these issues is crucial for making TEGs more economically viable and successful. One effective strategy is the implementation of MPPT algorithms, such as P&O algorithm. MPPT algorithms ensure that TEGs operate at their most optimal point under varying temperature conditions, therefore maximising energy conversion efficiency.

Thermoelectric Generator

TEGs are renewable energy devices constructed from semiconductor materials that directly convert thermal energy into electrical energy based on the Seebeck effect, which was initially proposed in 1821 by the scientist Thomas J. Seebeck (Jaziri et al., 2020; Verma & Sharma, 2019). The Seebeck effect occurs when two dissimilar metals are joined at different temperatures, generating an electromotive force that results in a voltage between across the junction (El-Shahat & Bhuiyan, 2021a; Patel & Singh, 2021; Zhang & Zhao, 2015).

A typical TEG consists of multiple pairs of thermoelectric materials that are connected electrically in series and thermally in parallel. These thermoelectric modules, also known as thermocouple, consists of two distinct materials with different thermoelectric properties (Stecanella et al., 2015). Typically, semiconductor alloys with different levels of thermal conductivity are commonly employed. In the TEG, multiple p-type and n-type couplings are electrically connected in series to increase the output voltage and thermally in parallel to decrease the thermal resistance as shown in Figure 1 (Yahya et al., 2018). These couples are positioned between two parallel ceramic plates, which provide structural strength, a flat mounting surface, and a dielectric layer to protect against electrical short circuits.

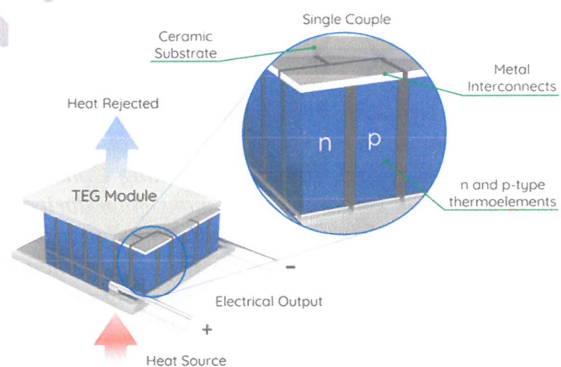

FIGURE 1. Structure of TEG consist of p-type and n-type thermoelements (Sharma et al., 2020; Shilpa et al., 2022)

The p-type elements are made from semiconductor materials that have been doped to create positive charge carriers (holes), resulting in a positive Seebeck coefficient. In contrast, the n-type elements are doped to negative charge carriers (electrons), leading to a negative Seebeck coefficient.

The thermoelectric effect involves the movement of electrons from one location to another due to a temperature gradient, as illustrated in Figure 2. TEGs are commonly used in situations where a

temperature gradient is present, such as in waste heat recovery from industrial processes, automotive exhaust systems, or even body heat harvesting in wearable devices (Hyland et al., 2016; Wang et al., 2009). By generating electricity from waste heat sources, TEGs contribute to improving overall energy efficiency.

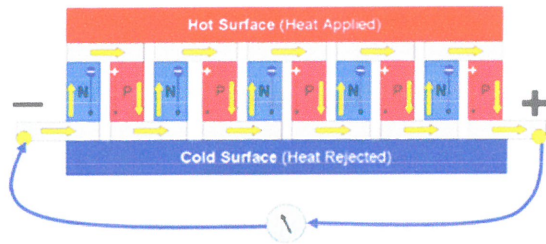

FIGURE 2. The movement of electron (Kumar, 2020)

When the temperatures of the hot and cold surfaces of a TEG differ, a voltage across the TEG is generated. The voltage produced is known as open circuit voltage (V_{oc}). V_{oc} generated by TEG formula is shown in Equation (1):

$$V_{oc} = N\alpha\Delta T \quad (1)$$

where N is the number of connected thermocouples, α is the Seebeck coefficient (V/K) of the materials used, and ΔT is the temperature difference ($^{\circ}\text{C}$), defined as:

$$\Delta T = T_h - T_c \quad (2)$$

where T_h is the hot side temperature, and T_c is the cold side temperature of the TEG. When there is no load resistance R_L across the TEG and ΔT is at its maximum, the V_{oc} reaches its peak value. The total TEG internal resistance R_{TEG} is proportional to N where increasing the number of series-connected thermocouples leads to an increase in the R_{TEG} . The output power delivered by the generator is expressed as:

$$P = V^2 \frac{R_L}{(R_{TEG} + R_L)^2} \quad (3)$$

When the R_L matches the R_{TEG} , the maximum output power is given by Equation (4):

$$P = \frac{v^2}{4R_{TEG}} \quad (4)$$

The voltage value at this point is known as the voltage at the maximum power point (V_{MPP}) where:

$$V_{MPP} = \frac{V_{oc}}{2} \quad (5)$$

The P-V curve as shown in Figure 3 illustrates the power-voltage characteristic of a TEG module. This curve represents the relationship between the electrical power output (P) and the voltage (V) across the TEG module at different temperature differentials. The P-V characteristics of a TEG are determined by measuring the power output and voltage across the TEG for various load resistances while maintaining a constant temperature difference across the thermoelectric elements. The red cross marker indicates the maximum power point (MPP).

MPPT Principle

MPPT controllers are categorized into three types based on control and optimization concepts: conventional techniques, modern intelligent techniques, and array reconfiguration schemes. Examples of conventional techniques include P&O, incremental conductance and Fuzzy Logic. The MPPT algorithm must be employed to compensate for the power reduction in energy harvesting systems. Many MPPT algorithms have been proposed and are commonly classified into the following groups, for example: (1) P&O methods; (2) Extremum Seeking Control (ESC) methods (Twaha, Zhu, Maraaba, et al., 2017); (3) Incremental Conductance (INC) methods (Esrām & Chapman, 2007).

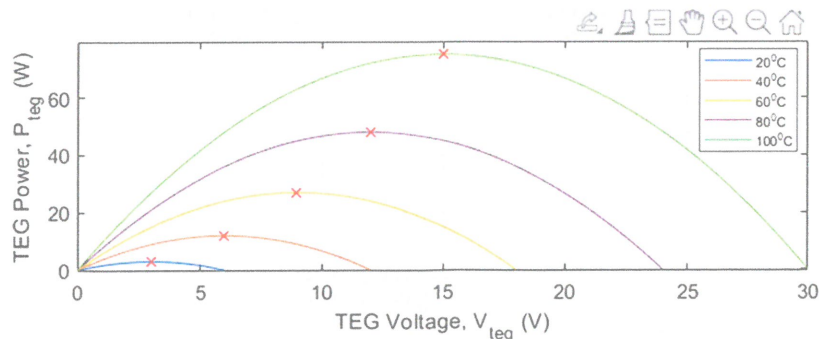

FIGURE 3. P-V curve for Thermoelectric generator

In (Twaha, Zhu, Yan, et al., 2017) paper, the INC and P&O methods of MPPT were simulated and analysed with a TEG and DC-DC converter. The results showed that the INC method has a higher voltage gain and converter efficiency than the P&O based MPPT method. However, INC approach resulted in lower efficiency in tracking the MPP than P&O method. The matching efficiency in the temperature range of 200 °C - 300 °C resulted range 99.92% - 99.95% for P&O method and 99.46% - 99.97% for INC method. This indicates that P&O method has better efficiency for tracking the MPP.

The P&O algorithm based on Kalman filter was designed and analysed by Yahya et al., 2018. The Kalman filter improved the P&O performance by overcoming the generated noise, which paves the implementation of the MPPT algorithm. In this paper, a TEG array is coupled to the load via a boost converter. The boost converter was selected due to its wide operating temperature range.

In (Mamur & Ahiska, 2015) paper, a DC-DC boost converter with MPPT based on a microcontroller in the P&O method was designed to obtain the MPP. The objective of this study was to compare the efficiency of a TEG system when a battery pack is connected directly to the TEG system versus when it is connected through the converter. The obtained result showed that the TEG system's efficiency is greater when the battery pack is connected through converter, achieving 92% efficiency compared to 55% when connected directly. This proves that the converter is a crucial component for TEG to operate at maximum efficiency.

In (Twaha, Zhu, Yan, et al., 2017) paper, a comparison between ESC MPPT method and P&O MPPT technique was modelled, simulated and tested using MATLAB/Simulink. The result showed that for load resistances range of 0 - 1.2 Ω, the output power difference tends to be negative. This indicates that the P&O technique outperforms the ESC method in terms of the amount of output power harvested in that range.

METHODOLOGY

Proposed Method

There are numerous different types of MPPT algorithm that can be used to determine the precise MPP. In this project, the P&O method is used due to its simplicity and ease of implementation (Sera et al., 2006) This method is the most common type used in the TEG system.

The P&O method operates by calculating the output power and introducing a perturbation (increase or decrease) that affects the system's output power. This is done by sampling the TEG's current and voltage. If the perturbation results in an increase in output power, the voltage is increased to further approach the MPP. Conversely, if the perturbation causes a decrease in output power, the voltage is decreased. This adjustment results in a change in the duty cycle, and the process is repeated until the MPP is reached.

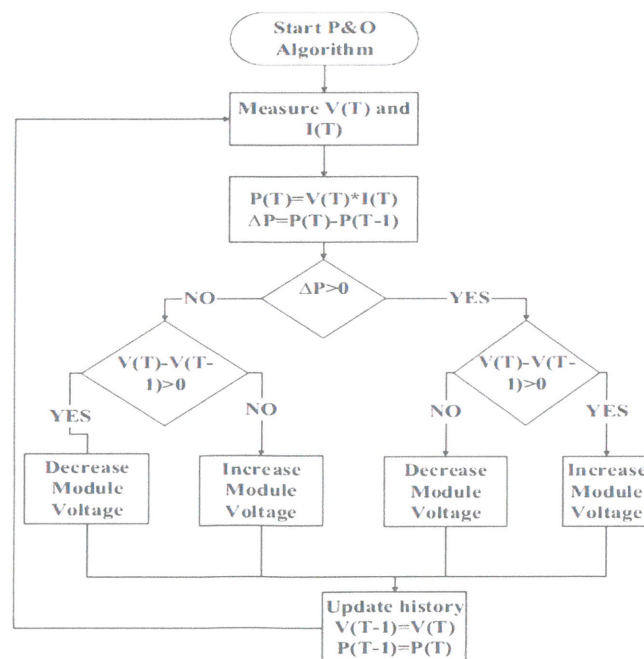

FIGURE 4. Flowchart of Perturb and Observe algorithm (El-Shahat & Bhuiyan, 2021)

Figure 4 shows the flowchart of the P&O algorithm operation. Initially, the voltage and current of the TEG module are measured, and then the power is calculated using these values. The calculated power is compared to the previous power value. If changes in power, ΔP is greater than zero, the program will verify the voltage difference ΔV in both circumstances to see if it is true or false after executing the building arrangement. Finally, it will update the new voltage and power values.

TEG Modelling

In this study, a TEG module based on the TEG manufactured by the TES ThermoElectric System is used. The properties of this module are shown in Table 1.

TABLE 1. Thermoelectric properties of a single TEG module

Properties	Values
Hot surface temperature, T_h	250 °C
Cold surface temperature, T_c	30 °C
Load matching resistance ($R_L = R_{TEG}$)	0.7 Ω
Seebeck coefficient, α	1.85 $\mu V/K$
Figure of merit, ZT	0.8

The modelling of a TEG system using a single TEG module through MATLAB/Simulink is shown in Figure 5. In this case, based on the Seebeck coefficient and the temperature difference, the output current, voltage, and power are obtained. This model is designed as a basis of the TEG system. In order to increase power generation from the TEG

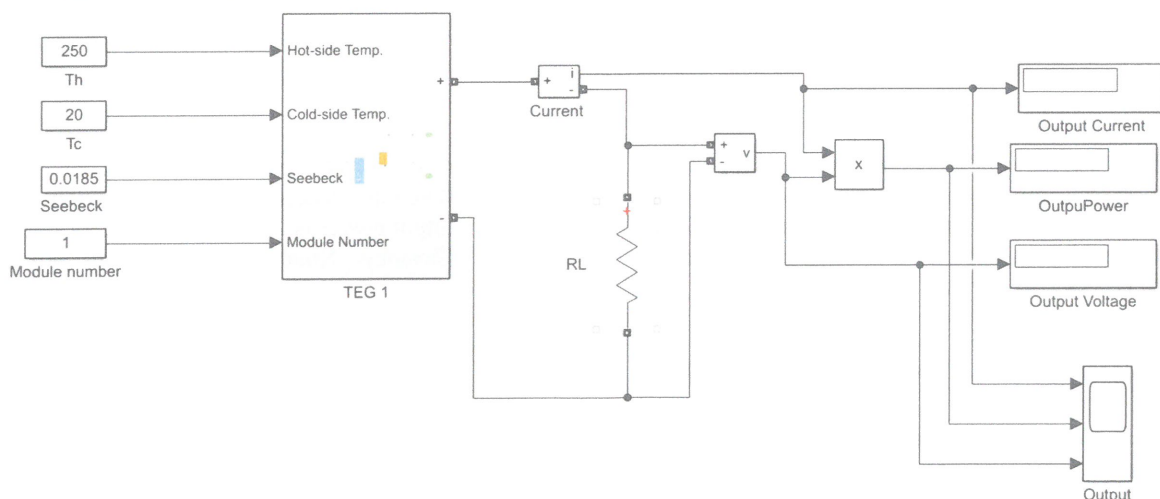

FIGURE 5. Model of TEG system using a single TEG module

system, two TEG modules are interconnected in both series and parallel configuration, as depicted in Figure 6. Each module consists of 20 serially connected TEG modules with the purpose of increasing the voltage value. In addition, these two modules are connected in parallel to further increase the current value. The total internal resistance value of the whole system is 7 Ω .

Since the power generated by the TEGs varies based on the voltage and current drawn by the load, it is imperative to employ MPPT technique to maximize the energy extraction from the TEG. Thus, to achieve this, the complete circuit of TEG with a DC/DC boost converter and P&O MPPT algorithm is shown in Figure 7. For simulation and verification of these three models, MATLAB/Simulink software is used.

RESULT AND DISCUSSION

The simulations presented in this study are divided into two conditions: (a) constant temperature and variable load resistance; (b) constant load resistance and variable temperature.

TEG Modelling Without MPPT

The results presented in Table 2 are obtained from TEG modelling without MPPT, under conditions of a variable load and a constant temperature difference. The cold side temperature is set at 20 °C, while the hot side is set at 250 °C. The load resistance is varied from 1 Ω to 100 Ω . In this simulation, the load resistance directly influences the power output of the TEG. The table clearly shows that the output voltage and output current of

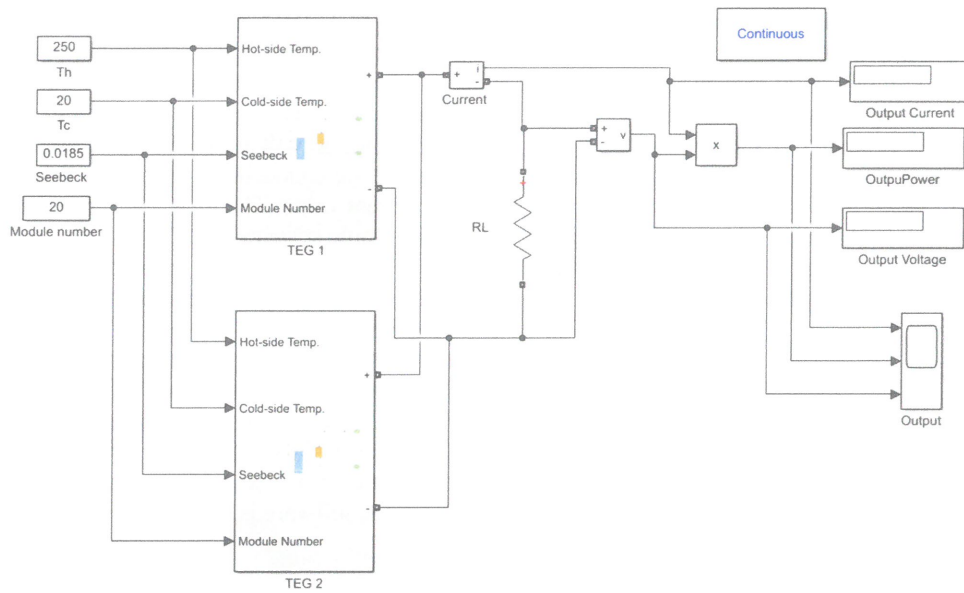

FIGURE 6. Two TEG modules connected in series-parallel combination (without MPPT).

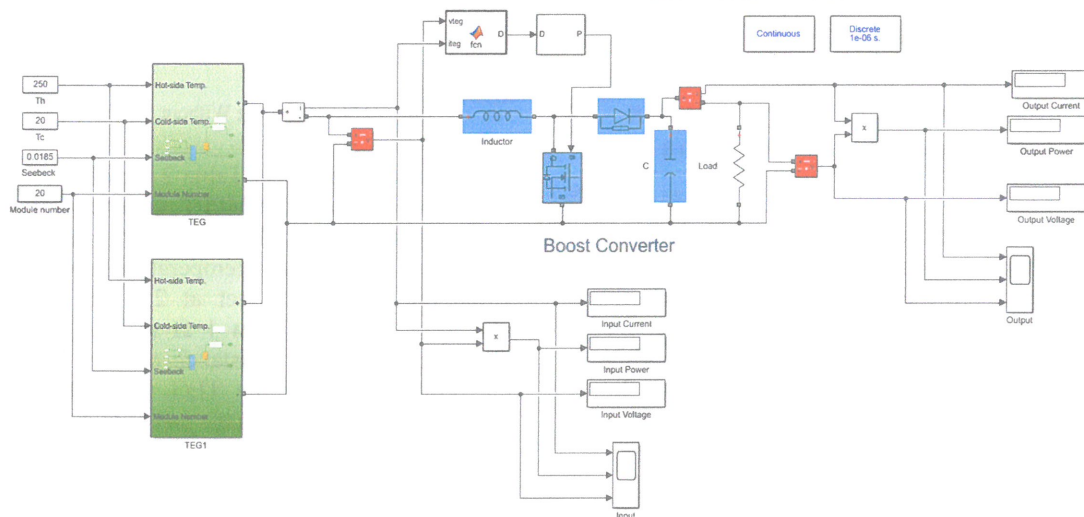

FIGURE 7. Two TEG modules connected in series-parallel combination with a P&O MPPT

the TEG increases and decrease respectively when the load resistance increases. The maximum power output of 258.6 W is achieved when the load resistance matches the TEG's internal resistance, which is 7 Ω .

TEG Modelling with Boost Converter P&O MPPT algorithm

Table 3 shows that, even without impedance matching, more than 90% of the power generated by the TEG can be successfully delivered to the output using MPPT. The results indicate that optimal MPPT performance is achieved with a load

resistance of 15 Ω , reaching an efficiency of 98.29%. When the system impedance is matched at 7 Ω , the output power is 249.8 W, corresponding to 97.6% efficiency. Notably, while output power decreased after 7 Ω impedance matching in the system without MPPT, no drastic drop was observed in the system with MPPT.

The power generated from the TEG system with and without MPPT is plotted as shown in Figure 8 for comparison. The blue line represents the power obtained from the system without MPPT, while the red line corresponds to the system with MPPT. In the system without MPPT, the output power drastically drops after the load resistance

TABLE 2. Output voltage, current and power of the TEG system without MPPT at various R_L

Load, R_L (Ω)	Cold side temperature T_c ($^{\circ}\text{C}$)	Hot side temperature T_h ($^{\circ}\text{C}$)	Output Voltage (V)	Output Current (A)	Output Power (W)
1			10.64	10.64	113.20
5			35.46	7.09	251.50
7			42.55	6.08	258.60
9			47.87	5.32	254.60
15	20	250	58.02	3.87	224.40
30			69.00	2.30	158.70
50			74.65	1.49	111.40
75			77.84	1.04	80.78
100			79.53	0.80	63.25

TABLE 3. Voltage, current and power of the TEG system with P&O MPPT at various R_L

Load, R_L (Ω)	Cold side temperature T_c ($^{\circ}\text{C}$)	Hot side temperature T_h ($^{\circ}\text{C}$)	Input Voltage (V)	Output Voltage (V)	Input Current (A)	Output Current (A)	Input Power (W)	Output Power (W)	MPPT (%)
1			9.30	9.56	10.83	10.64	100.70	91.37	90.73
5			31.36	34.13	7.68	35.46	240.80	233.00	96.76
7			38.26	41.82	6.70	42.55	256.00	249.80	97.58
9			43.51	47.80	5.94	47.87	258.50	253.80	98.18
15	20	250	44.91	61.66	5.74	58.02	257.80	253.40	98.29
30			46.62	86.91	5.50	69.00	256.30	251.80	98.24
50			46.95	111.70	5.45	74.65	255.90	249.50	97.50
75			48.34	136.50	5.25	77.84	253.90	245.00	96.50
100			48.53	154.20	5.22	79.53	253.80	237.70	93.77

reaches 7 Ω . In contrast, the system with MPPT exhibits a gradual decrease in power from 7 Ω up to 100 Ω . The graph also reveals that as the load increases beyond the impedance matching point of 7 Ω , the power output continues to decrease.

The results for the TEG system with MPPT are detailed in Table 4. In this modelling, the load resistance is kept constant at 7 Ω and the cold side temperature at 20 $^{\circ}\text{C}$. Meanwhile, the hot side temperature is varying from 30 $^{\circ}\text{C}$ to 250 $^{\circ}\text{C}$. The findings indicate that the power output at small temperature differences is sufficient to power low power electronic devices. However, as the temperature difference increases, the power output rises significantly. Additionally, while the power transfer efficiency of the MPPT system is reduced at smaller temperature differences, it improves at larger temperature differences. These results highlight the effectiveness of increasing the temperature gradient in enhancing the power output of the TEG system.

TEG System with MPPT Depending on Time

In Figure 9, the hot side of the TEG is maintained at a constant temperature of 250 $^{\circ}\text{C}$, while the cold side is set to 20 $^{\circ}\text{C}$. The system is initially operated at a

load resistance of 7 Ω , and then the load is increased to 100 Ω . When operating at 7 Ω , the system takes 0.2s to reach MPP. However, when the load is changed to 100 Ω the time taken to find the MPP is more than 0.3s. Conversely, when the load is changed from 7 Ω to 15 Ω , the time taken to reach MPP is only 0.1s, as shown in Figure 10. This indicates that small changes in load results in shorter times to reach the MPP.

The system in Figure 11 is set to operate at constant load while the temperature is varied. Initially, the temperature is set at 10 $^{\circ}\text{C}$ and gradually increased to 250 $^{\circ}\text{C}$. The graph shows that the time taken for the hot side temperature of 10 $^{\circ}\text{C}$ is 0.3 s to find the MPP. When the temperature is increased to 250 $^{\circ}\text{C}$, the time taken for the system to find the MPP is 0.1s. Additionally, Figure 12 shows that the temperature is increasing from 200 $^{\circ}\text{C}$ to 250 $^{\circ}\text{C}$, and the time taken to obtain MPP is less than 0.1 s. This demonstrates that the higher temperature changes lead to shorter times for the system to reach MPP. The simulation results confirm that the TEG module performs more efficiently when coupled with a DC-DC boost converter and the P&O MPPT technique. This is evidenced by the power output obtained in the simulations shown in Figures 13 and 14.

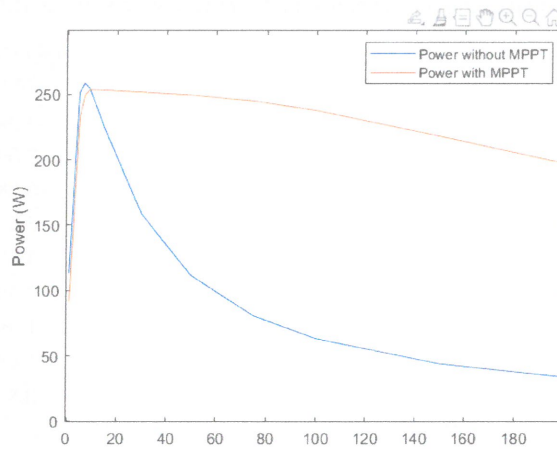

FIGURE 8. Power without MPPT and Power with MPPT graph

TABLE 4 Voltage, current and power of the TEG system with P&O MPPT at various temperature

Load, R_L (Ω)	Cold side temperature T_c ($^{\circ}\text{C}$)	Hot side temperature T_h ($^{\circ}\text{C}$)	Input Voltage (V)	Output Voltage (V)	Input Current (A)	Output Current (A)	Input Power (W)	Output Power (W)	MPPT (%)
7	20	30	1.91	1.49	0.26	0.21	0.49	0.32	64.90
		50	5.34	5.15	0.82	0.74	4.39	3.79	86.25
		70	9.65	8.85	1.26	1.26	12.20	11.19	91.72
		90	13.56	12.55	1.79	1.79	23.93	22.50	94.02
		110	15.22	16.15	2.85	2.30	39.31	37.26	94.79
		130	20.75	19.95	2.85	2.85	59.14	56.85	96.12
		150	21.80	23.48	3.76	3.36	81.91	78.79	96.19
		175	25.91	28.07	4.49	4.01	116.40	112.5	96.65
		200	30.03	32.65	5.22	4.66	156.90	152.3	97.07
		250	38.26	41.82	6.69	5.97	256.00	249.8	97.58

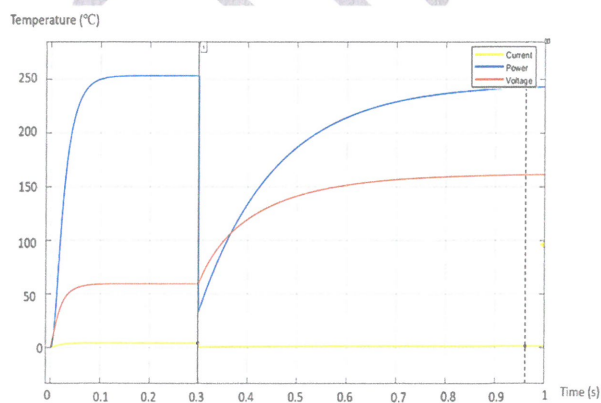

FIGURE 9. Simulation result when load changes from 7 Ω to 100 Ω

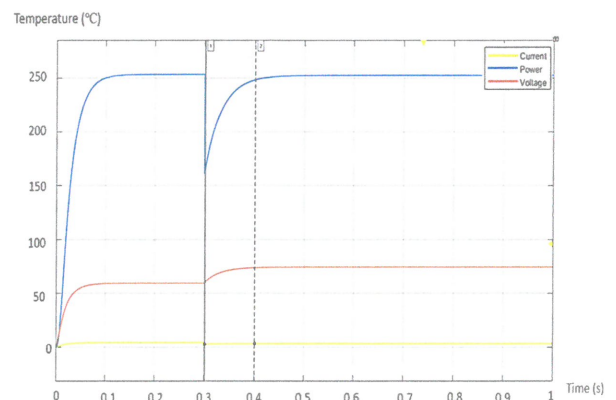

FIGURE 10. Simulation result when load changes from 7 Ω to 15 Ω

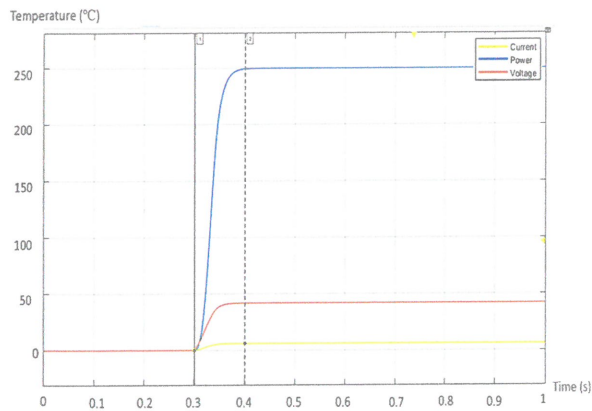

FIGURE 11. Simulation result when temperature changes from 10 °C to 250 °C

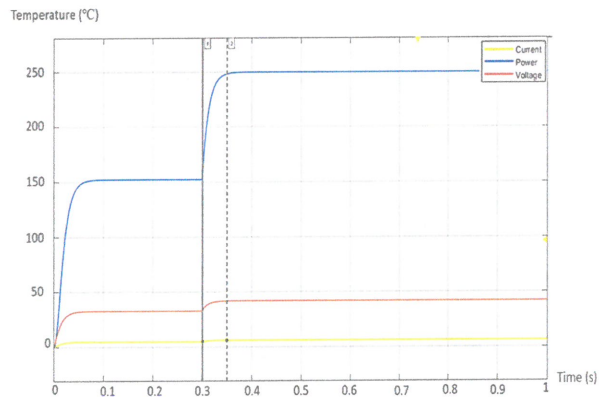

FIGURE 12. Simulation result when temperature changes from 200 °C to 250 °C

CONCLUSION

This study proved that employing the P&O method for MPPT significantly enhances the power generation and efficiency of TEGs. Improving TEG efficiency through P&O MPPT algorithm addresses critical challenges in energy conversion and sustainability, offering both economic and technological benefits. Moreover, the widespread adoption of thermoelectric power generation can contribute to a cleaner environment by reducing pollution. Future research should focus on developing new thermoelectric materials and advancing technologies to fully optimize TEG applications. Embracing thermoelectricity as a highly efficient and environmentally friendly energy source is essential for achieving sustainable energy goals. Engineers and designers should conduct more research and development to minimize waste heat and enhance the performance of TEG systems. This study not only improves the practical applications of TEGs, but also contributes to the larger goals of sustainable energy development and technical innovation.

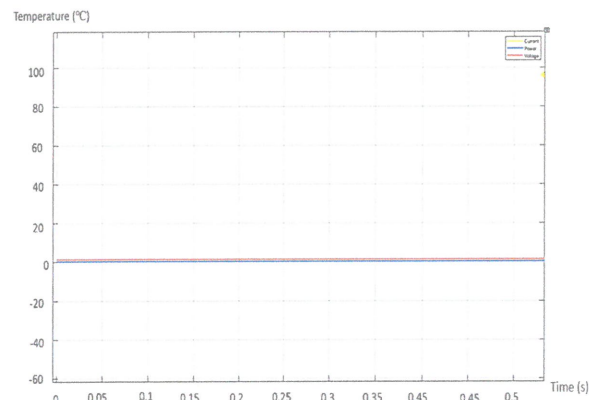

FIGURE 13. Simulation result from TEG system without MPPT

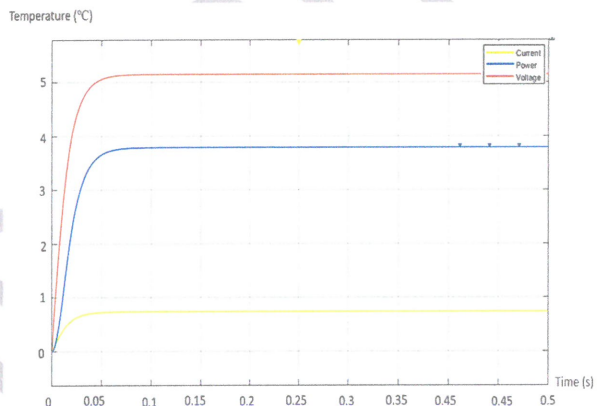

FIGURE 14. Simulation result from TEG system with MPPT

REFERENCES

- Ahiska, R., & Mamur, H. (2014). A review: Thermoelectric generators in renewable energy. In *INTERNATIONAL JOURNAL of RENEWABLE ENERGY RESEARCH Hayati Mamur et al* (Vol. 4, Issue 1).
- Champier, D. (2017). Thermoelectric generators: A review of applications. In *Energy Conversion and Management* (Vol. 140, pp. 167–181). Elsevier Ltd.
- Chen, W. H., Wu, P. H., Wang, X. D., & Lin, Y. L. (2016). Power output and efficiency of a thermoelectric generator under temperature control. *Energy Conversion and Management*, 127, 404–415.
- El-Shahat, A., & Bhuiyan, M. S. R. (2021a, January 21). Thermoelectric Generator Performances and Efficiency Analysis Integrated with MPPT Techniques. *2021 International Conference on Sustainable Energy and Future Electric Transportation, SeFet 2021*.
- El-Shahat, A., & Bhuiyan, M. S. R. (2021b, January 21). Thermoelectric Generator Performances

- and Efficiency Analysis Integrated with MPPT Techniques. *2021 International Conference on Sustainable Energy and Future Electric Transportation, SeFet 2021*.
- Esrām, T., & Chapman, P. L. (2007). Comparison of photovoltaic array maximum power point tracking techniques. *IEEE Transactions on Energy Conversion*, 22(2), 439–449.
- Hyland, M., Hunter, H., Liu, J., Veety, E., & Vashae, D. (2016). Wearable thermoelectric generators for human body heat harvesting. *Applied Energy*, 182, 518–524.
- Jaziri, N., Boughamoura, A., Müller, J., Mezghani, B., Tounsi, F., & Ismail, M. (2020). A comprehensive review of Thermoelectric Generators: Technologies and common applications. In *Energy Reports* (Vol. 6, pp. 264–287). Elsevier Ltd.
- Jouhara, H., Żabnieńska-Góra, A., Khordehghah, N., Doraghi, Q., Ahmad, L., Norman, L., Axcell, B., Wrobel, L., & Dai, S. (2021). Thermoelectric generator (TEG) technologies and applications. In *International Journal of Thermofluids* (Vol. 9). Elsevier B.V.
- Kumar, P. (2020). THERMOELECTRIC POWER GENERATION BY BIKE SILENCER. *International Research Journal of Engineering and Technology*. www.irjet.net
- Mamur, H., & Ahiska, R. (2015). Application of a DC-DC boost converter with maximum power point tracking for low power thermoelectric generators. *Energy Conversion and Management*, 97, 265–272.
- Mamur, H., & Çoban, Y. (2020). Detailed modeling of a thermoelectric generator for maximum power point tracking. *Turkish Journal of Electrical Engineering and Computer Sciences*, 28(1), 124–139.
- Miao, J., Chen, H., Lei, Y., Lv, Y., Liu, W., & Song, Z. (2021). Mppt circuit using time exponential rate perturbation and observation for enhanced tracking efficiency for a wide resistance range of thermoelectric generator. *Applied Sciences (Switzerland)*, 11(10).
- Patel, J., & Singh, M. (2021). Thermoelectric Generators. In *Open Science Journal*.
- Polibatam (Organization), Institute of Electrical and Electronics Engineers. Indonesia Section. CSS/RAS Joint Chapter, & Institute of Electrical and Electronics Engineers. (n.d.). *Proceedings of the 2018 International Conference on Applied Engineering (ICAE) : Batam, Indonesia, October 3-4, 2018*.
- Sera, D., Kerekes, T., Teodorescu, R., & Blaabjerg, F. (2006). Improved MPPT method for rapidly changing environmental conditions. *IEEE International Symposium on Industrial Electronics*, 2, 1420–1425.
- Sharma, P., Chaudhary, R., & Agrawal, G. (2020). Issue 4 www.jetir.org (ISSN-2349-5162). In *JETIR2004368 Journal of Emerging Technologies and Innovative Research* (Vol. 7). www.jetir.org
- Shilpa, M. K., Raheman, M. A., Aabid, A., Baig, M., Veeresha, R. K., & Kudva, N. (2022). A Systematic Review of Thermoelectric Peltier Devices: Applications and Limitations. *Fluid Dynamics and Materials Processing*, 19(1), 187–206.
- Stecanella, P. A. J., Faria, M. A. A., Domingues, E. G., Gomes, P. H. G., Calixto, W. P., & Alves, A. J. (2015). Electricity generation using thermoelectric generator - TEG. *2015 IEEE 15th International Conference on Environment and Electrical Engineering, EEEIC 2015 - Conference Proceedings*, 2104–2108.
- Twaha, S., Zhu, J., Maraaba, L., Huang, K., Li, B., & Yan, Y. (2017). Maximum power Point Tracking control of a thermoelectric generation system using the extremum seeking control method. *Energies*, 10(12).
- Twaha, S., Zhu, J., Yan, Y., Li, B., & Huang, K. (2017). Performance analysis of thermoelectric generator using dc-dc converter with incremental conductance based maximum power point tracking. *Energy for Sustainable Development*, 37, 86–98.
- Verma, G., & Sharma, V. (2019). A Novel Thermoelectric Energy Harvester for Wireless Sensor Network Application. *IEEE Transactions on Industrial Electronics*, 66(5), 3530–3538.
- Wang, Z., Leonov, V., Fiorini, P., & Van Hoof, C. (2009). Realization of a wearable miniaturized thermoelectric generator for human body applications. *Sensors and Actuators, A: Physical*, 156(1), 95–102.
- Yahya, K., Bilgin, M. Z., Erfidan, T., & Çakir, B. (2018). Improving the performance of the MPPT for thermoelectric generator system by using Kalman filter. *2018 5th International Conference on Electrical and Electronics Engineering, ICEEE 2018*, 129–132.
- Zhang, X., & Zhao, L. D. (2015). Thermoelectric materials: Energy conversion between heat and electricity. In *Journal of Materiomics* (Vol. 1, Issue 2, pp. 92–105). Chinese Ceramic Society.